

Solutions for today, Innovations for tomorrow.

SAUSAGE CUTTING MACHINE

 **HI-CUT 2**



HITEC

www.hitec-jp.com

**A new model has been launched from the sausage cutter.
HI-CUT 2 realizes the precise cutting with high speed.
The counter function is available as the conventional model.**



SAUSAGE CUTTING MACHINE
HI-CUT 2



- Hygienic design
- Stainless steel construction for long product life
- Designed for food safety



- Precise cutting



- Adjustable belt for stable intake and discharge
- Easy cutting adjustment



- Comfortable and simple operation
- Counting function equipped



- Suitable for natural, collagen and cellulose casings
- Suitable for cooked sausages
- Suitable also for fresh sausages



■ LAYOUT

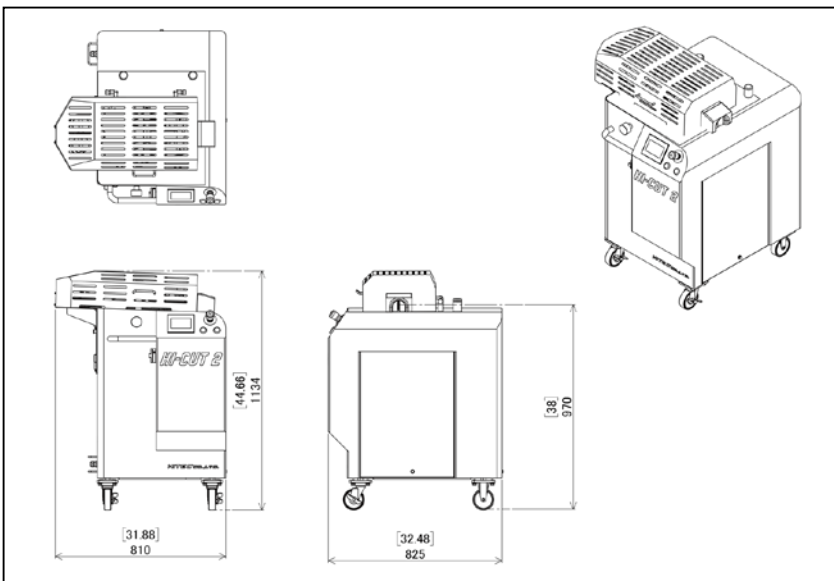

■ SPECIFICATION

	HI-CUT 2
Conveyer Speed	0.25~2.1 m / s
Cutting Capacity	1,800 pieces / min
Casing Size	φ 10 mm ~ 50 mm
Power Requirements	Single phase 200V 1.5kW
Height	970 mm (38 3/16 in)
Width	810 mm (31 57/64 in)
Length	825 mm (32 31/64 in)
Weight	Approx. 310 kg (684 lbs)

※ Specifications and equipment are subject to change without any obligation on part of the manufacturer.
 ※ The above production rate changes subject to the conditions such as production item, factory and other conditions.

HITEC CO., LTD.
HEAD OFFICE & FACTORY
 2565-8, NAGATSUTA-CHO, MIDORI-KU, YOKOHAMA 226-0026, JAPAN
 PHONE +81-45-983-5000 FAX +81-45-983-0020
 E-mail : sales@hitec-jp.com URL : www.hitec-jp.com

HITEC CO., LTD.

