

Solutions for today, Innovations for tomorrow.

SAUSAGE HIGH SPEED LINKING AND HANGING SYSTEM

 **JACKWEL**



HITEC

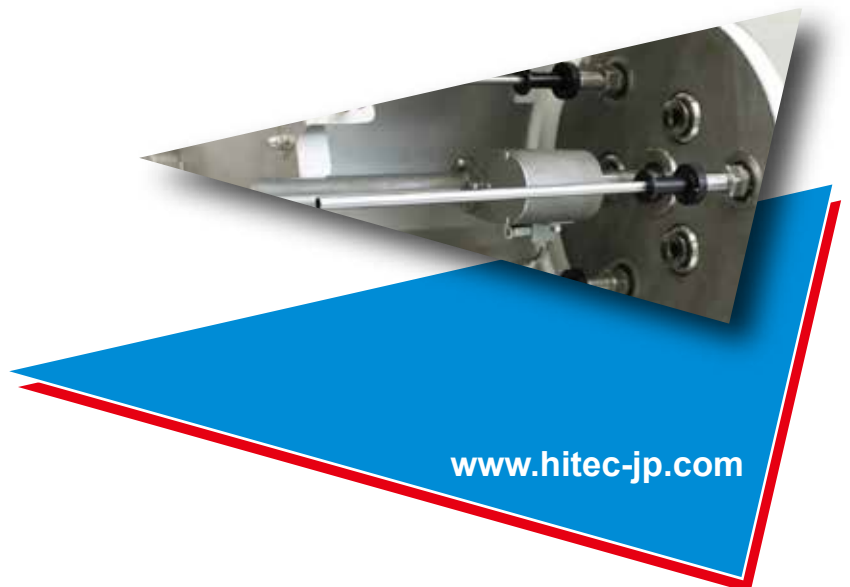

www.hitec-jp.com

New !
aiming for the fastest
ever stuffing machine.



JACKWEL

SAUSAGE HIGH SPEED LINKING AND HANGING SYSTEM

- It is a revolutionary equipment that can perform over 1,000 pieces a minute and can produce equal length, equal weight sausages by two operators.
- Even without the linking chain, JACKWEL makes it possible to make a certain length products with natural casings by using two butterfly wings for twisting and the upper and lower belts for transfer.
- One of the features of this portioning system is you can freely change the product length and weight without linking chain.
- Collagen casing is available too. (Manual insertion)



▶ **Operator Friendly Monitor**

- Easy changing of products
- Production control
- Maintenance and troubleshooting



▶ **Multi stuffing tube revolver head**

The multi stuffing tube turret (revolver head) allows:

- pre-feeding of natural casings
- up to 30% increased production output
- faster cycle times
- reduced machine stopping / waiting time

■ **LAYOUT**

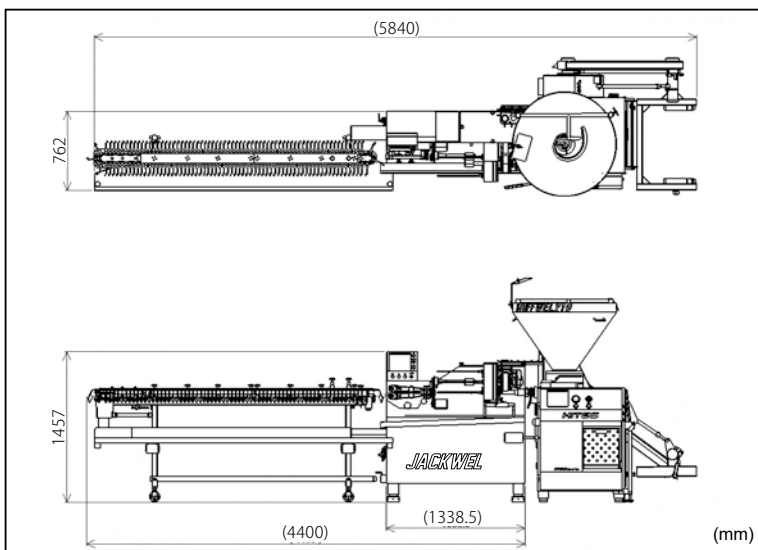

■ **SPECIFICATION**

	JACKWEL
Production Rate	Natural Casing Max 1000 pcs/min
Production Size	25 - 1,200 mm
Casing Size	13 mm - 36 mm
Height	1,457 mm (57 23/64 in)
Width	762 mm (30 in)
Length	4,400 mm (173 15/64 in)
Weight	Approx 500 kg (1,102 lbs)
Power Requirements	Three - phase, 4.2 kw (without Power of Stuffwel)
Pneumatic Requirements	Pressure 0,5 Mpa (75psi)

※ Specification and equipment are subject to change without any obligation on part of the manufacturer.

※ The above production rate is subject due to the conditions such as production item, factory and other conditions.

HITEC CO., LTD.
 HEAD OFFICE & FACTORY
 2565-8, NAGATSUTA-CHO, MIDORI-KU, YOKOHAMA 226-0026, JAPAN
 PHONE +81-45-983-5000 FAX +81-45-983-0020
 E-mail : sales@hitec-jp.com
 URL : www.hitec-jp.com

HITEC CO., LTD.



Scan QR code for Video.

20240626 Ver.3