

■ LAYOUT

STUFFWEL 219L

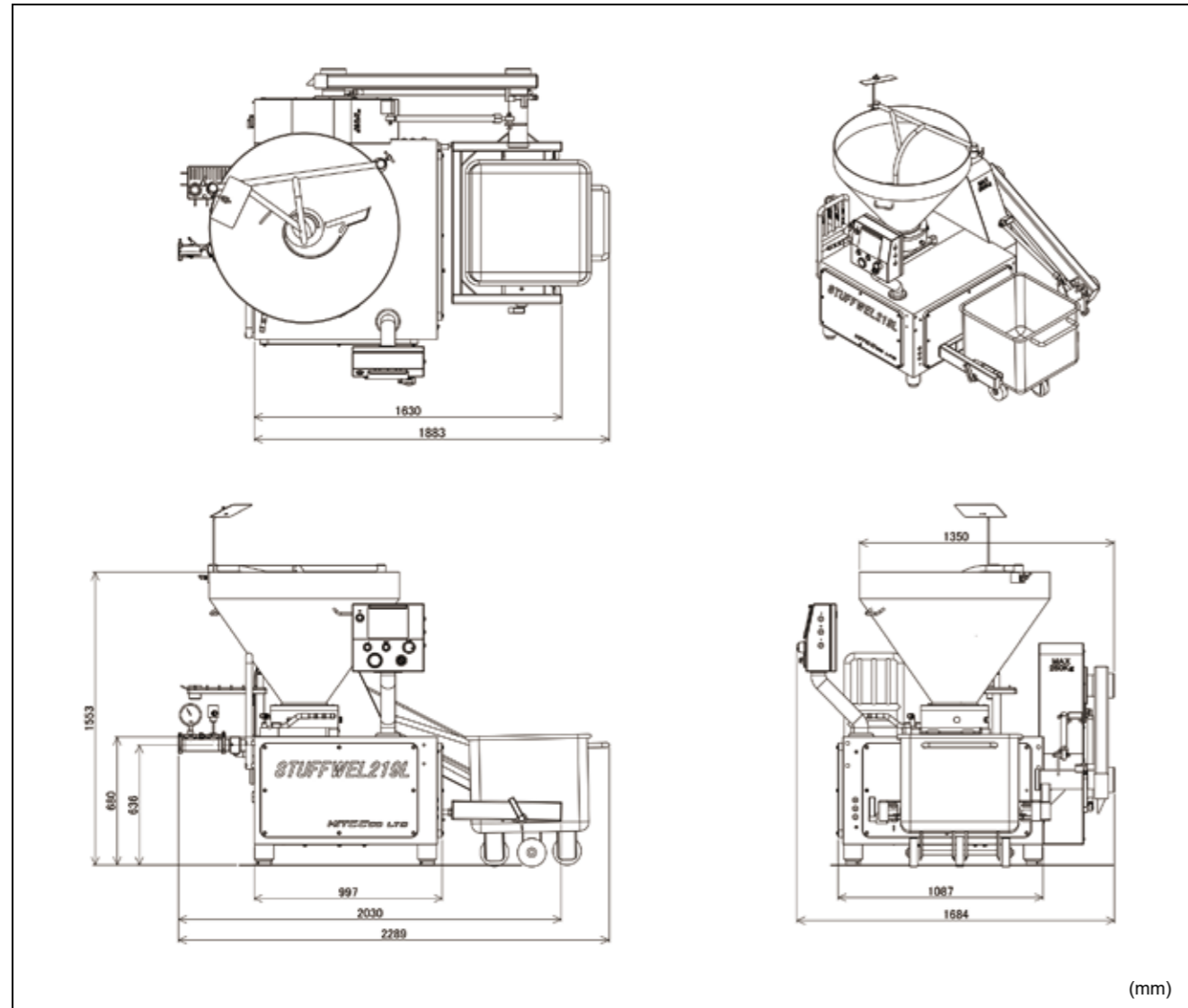

※ Layout dimension includes dimension of optional equipment

■ SPECIFICATION

	STUFFWEL 219L	STUFFWEL 219L & Lifting Device
Filling Capacity	up to 3,000 kg/h	
Filling Pressure	up to 40 bar	
Portioning Range	4.0g ~ 9,999.9 g	
Hopper Capacity	300 L	
Height	1,553 mm (61 9/64 in)	1,553 mm (61 9/64 in)
Depth	1,265 mm (49 51/64 in)	1,684 mm (66 19/64 in)
Length	1,399 mm (55 5/64 in)	2,030 mm (79 59/64 in)
Weight	Approx. 700 kg	Approx. 925 kg
Power Requirements	Three-phase 200 V 4.8 kW	Three-phase 200 V 6.25 kW

※ The figures shown above may change depending on the product, plant condition, local requirements for power and/or other respective matters.
 ※ Specifications and equipment are subject to change without any obligation on the part of manufacturer.

HITEC CO., LTD.
 HEAD OFFICE & FACTORY
 2565-8, NAGATSUTA-CHO, MIDORI-KU, YOKOHAMA 226-0026, JAPAN
 PHONE +81-45-983-5000 FAX +81-45-983-0020
 E-mail : sales@hitec-jp.com URL : www.hitec-jp.com

HITEC CO., LTD.

20231023 Ver.2

Solutions for today, Innovations for tomorrow.

VACUUM FOOD TRANSFER PUMP - LOW FLOOR TYPE

STUFFWEL 219L



HITEC



www.hitec-jp.com

**High Performance,
High precision
VACUUM FOOD TRANSFER PUMP.**

**Lower body height and hopper.
Easy to check meat inside the hopper.
Good for lower ceiling factory.**



VACUUM FOOD TRANSFER PUMP - LOW FLOOR TYPE

STUFFWEL 219L



For the constant pressured operation with high speed linking and hanging system LINKWEL, MACHWEL and etc. Not only that, it is also good to connect hamburg former and to pump the viscous stuff etc.

◀ Vane Pump

Due to the new type vane pump, it is accomplished to convey products without damaging such as crushing and breaking into pieces.

◀ Servo Drive Control

By adapting the state-of-art servo system, the exact weight control along with smooth and gentle operation are perfected with precision .

◀ Vacuum system for the pump

Vacuum system brings smooth flow of material from the hopper by making the inside of pump vacuum state, which keeps the material good quality. It is designed for low yield rate of material.



◀ Operator Friendly Monitor

All your necessary information displayed at the touch of a button.

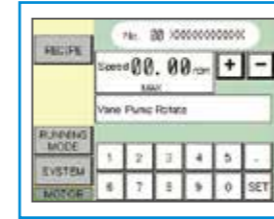

◀ Production Control

All vital data including cycles run, set points, etc. can be checked at anytime.

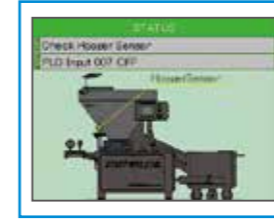

◀ Maintenance and troubleshooting

If any problems occur during operation, the display will show the location of the fault.

Option



◀ Constant Pressure Device (PID Device), Pressure Gauge

The equipment feeds meat with controlled pressure to other process equipment.

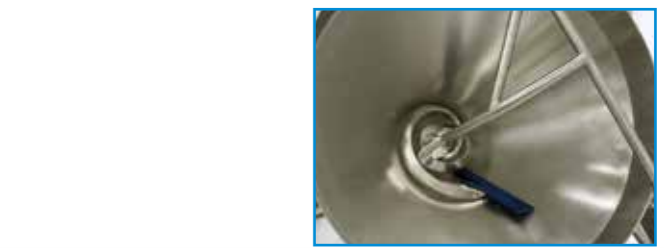

◀ Foldable Hopper with Screw Feeder

Hopper is internally equipped with Screw Feeder. It makes to use up all meat without waste. Also, since Hopper is foldable, it is easy and simple to wash.

◀ Pump Specification

The STUFFWEL 219L can also be used as a meat transfer pump by using PID device and controlling the meat pressure inside the piping.

The layout above is an example of Hitec MACHWEL machine. One STUFFWEL 219L can be connected to multiple linking and hanging machines.

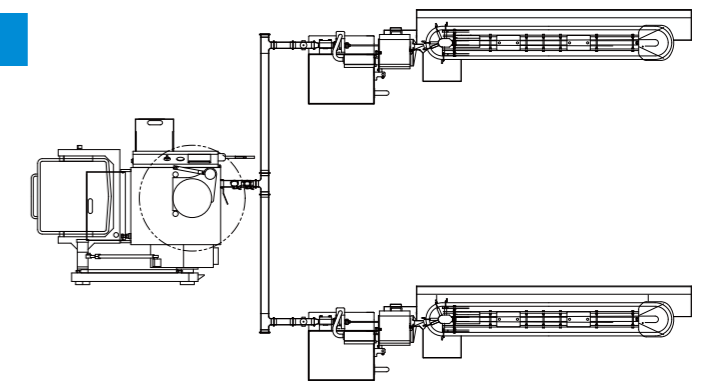

◀ Layout sample of the forming line

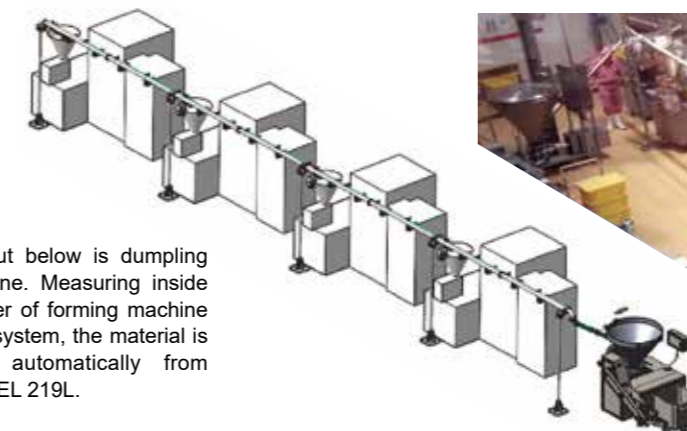

The layout below is dumping forming line. Measuring inside the hopper of forming machine by razor system, the material is supplied automatically from STUFFWEL 219L.

