

Solutions for today, Innovations for tomorrow.

SAUSAGE CUTTING MACHINE

SAUSAGE CUTTER



HITEC



www.hitec-jp.com

Introducing the next level of performance, the HITEC Sausage Cutter.

SAUSAGE CUTTING MACHINE

SAUSAGE CUTTER



Developed with a mechanical simplicity and dependability surpassing all other machines, the SAUSAGE CUTTER sets new standards in productivity. This machine adopts the most advanced technology to allow complete control of your process.

- Small sized and light weight
- Reliable and precise cutting rates
- Cuts straight or curved cooked sausages in natural, collagen and cellulose casings
- Easy setting of the cutting position
- Integrated counting system to cut each individual sausage or cutting of sausage groups
- Fully adjustable in-feed and discharge belts for reliable guidance of sausage
- All stainless steel construction. Type 304, 2B finish. Entire system designed for lasting equipment longevity and highest food safety in mind

■ LAYOUT

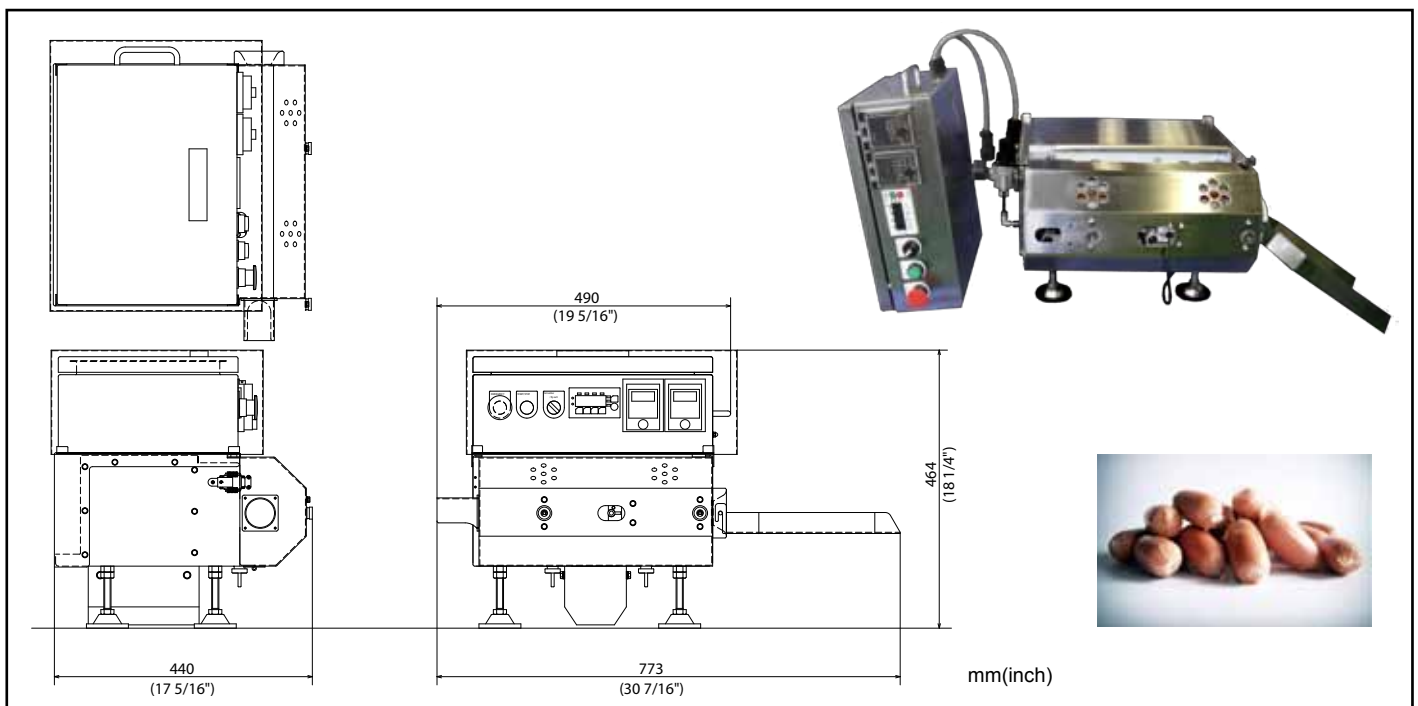

■ SPECIFICATION

| | SAUSAGE CUTTER |
|------------------------|---|
| Conveyer Speed | 42 meters / 137 ft. per minute |
| Cutting Capacity | 600 pieces / min @ 70 mm / 2 3/4" link length |
| Casing Size | φ 15 mm - 35 mm |
| Power Requirements | Single phase 200V 150W |
| Pneumatic Requirements | 0.5 MPa |
| Height | 18 1/4 in / 464 mm |
| Width | 19 5/16 in / 490 mm |
| Length | 17 5/16 in / 440 mm |
| Weight | Approx. 40 kg / 89 lbs. |

※ Specifications and equipment are subject to change without any obligation on part of the manufacturer.

※ The above production rate changes subject to the conditions such as production item, factory and other conditions.

HITEC CO., LTD.
HEAD OFFICE & FACTORY
 2565-8, NAGATSUTA-CHO, MIDORI-KU, YOKOHAMA 226-0026, JAPAN
 PHONE +81-45-983-5000 FAX +81-45-983-0020
 E-mail : sales@hitec-jp.com URL : www.hitec-jp.com

HITEC CO., LTD.